

## SolarTech Power Solutions

# US Industrial Energy Storage Battery Models

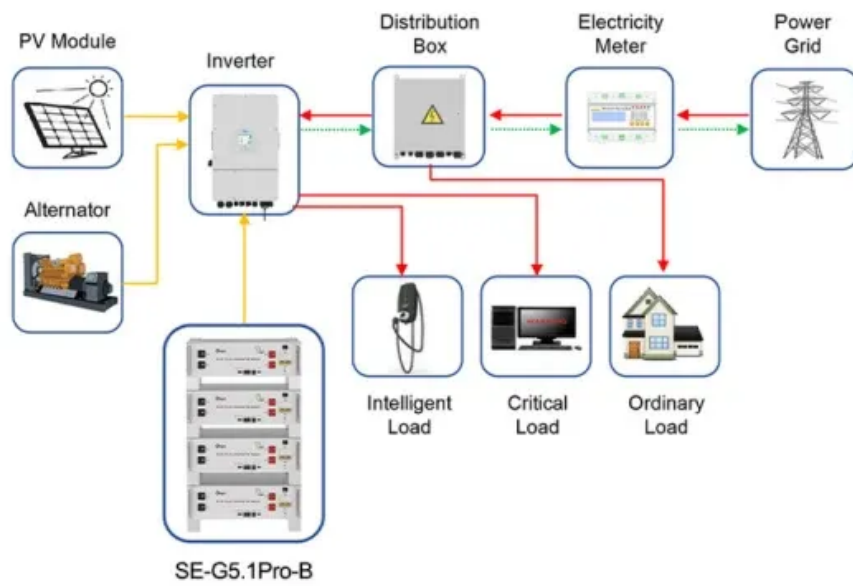

**Application scenarios of energy storage battery products**



## Overview

---

What are base year costs for utility-scale battery energy storage systems?

Base year costs for utility-scale battery energy storage systems (BESSs) are based on a bottom-up cost model using the data and methodology for utility-scale BESS in (Ramasamy et al., 2023). The bottom-up BESS model accounts for major components, including the LIB pack, the inverter, and the balance of system (BOS) needed for the installation.

How big is the utility-scale battery storage market?

The utility-scale storage market in the U.S. is experiencing unprecedented momentum. According to the U.S. Energy Information Administration (EIA), installed utility-scale battery storage capacity surpassed 15 GW in 2024 and is projected to more than double by 2026, with significant contributions from California, Texas, and Arizona.

Are batteries a key component of battery energy storage systems?

Batteries form a major key component of battery energy storage systems. Large-scale renewable energy installation in the U.S. economy will lead to enhanced deployment of battery energy storage systems in order to prevent intermittent power supply from renewable sources.

Are utility-scale battery energy storage systems a key enabler?

Introduction As the U.S. accelerates its transition toward a cleaner, more resilient energy grid, utility-scale battery energy storage systems (BESS) are emerging as a critical enabler of this transformation.

What is a battery energy storage value chain?

In the U.S. market, the value chain is characterized by equipment suppliers, battery energy storage manufacturers, and end-use markets. Battery energy storage system utilizes batteries, module packs, connectors, cables, and bus bars as a part of the manufacturing process. Batteries form a major key

component of battery energy storage systems.

How do battery storage systems improve grid resilience?

ing supply and demand (see Figure 9). However, battery storage systems helped bridge the gap by providing stored energy when solar generation was unavailable, demonstrating their importance in enhancing grid resilience and ensuring uninterrupted energy supply, especially in regions heavil

## US Industrial Energy Storage Battery Models

---

### Contact Us

---

For catalog requests, pricing, or partnerships, please visit:  
<https://www.zegrzynek.pl>